



Manual

RIM-7499-BOM

Version: 20200309

Status: Final

Confidentiality: Not confidential

Date: 09 March 2020

Author: Ludovic Grosjean

Document history

The Observator range is in continuous development and so specifications may be subject to change without prior notice. When in doubt about the accuracy of this document, contact the Observator Group.

Reference documents

Type of document / tool	Product type and name (incl. url)
Manual	RIM-7499-BOM

Revision history

Date	Amendments	Company, position
2017-07-31	Initial document creation	Observator Australia, Document Controller
2017-10-24	Warranty conditions	Observator Australia, Document Controller
2018-04-09	Introduced document control	Observator Australia, Document Controller
2019-02-15	Removed bucket refurbishment kit requirement in the maintenance section	Observator Australia, Document Controller
2019-07-15	Quality review	Observator Australia, Operation Manager
2019-08-23	Update pictures & compress document	Observator Australia, Document Controller
2019-12-18	Replaced rain gauge calibration certificate	Observator Australia, Document Controller
2020-01-30	Updated document format	Observator Australia, Document Controller
2020-03-09	Updated links	Observator Australia, Document Controller

Procedure sign-off:

Date	Company, position	Status
2019-02-15	Observator Australia, Document Controller	Finished
2019-12-06	Observator Australia, Managing Director	Approved
2020-02-10	Observator Group, Communication Officer	Approved

Distribution list

Date	Company, position
------	-------------------

Summary

Thank you for purchasing the new RIM-7499-BOM rain gauge. It will give you years of service if you install and maintain it according to the guidelines set out in this manual.

The RIMCO-7499 range of siphon-controlled tipping bucket rain gauges are designed and constructed for long-term operation with minimal maintenance under almost all climatic conditions. All materials used are corrosion resistant. These proven instruments are accurate to BOM standards.

RIM-7499-BOM key features:

- Rugged and corrosion resistant construction.
- Low friction, non-seizing bucket bearings.
- Gold plated buckets for minimal retention.
- Reed switch output with dual switch option.
- Stable calibration.
- Built-in bubble level.
- Optional self-powered internal counter.
- Optional heater allowing operation below -30°C.

RIMCO-7499 rain gauges are manufactured to exact standards, including those of the Australian Bureau of Meteorology (BOM) requirements.

Table of contents

1	Applications	5
2	Safety	6
3	Specifications.....	7
4	Wiring diagram.....	9
5	What you will find in the box.....	10
6	Accessories.....	11
7	Installation.....	13
7.1	Installing the rain gauge	13
	7.1.1 Site selection.....	13
	7.1.2 Installation	14
	7.1.3 Operation	15
8	Operation theory	16
9	Maintenance	17
9.1	Maintenance strategy	17
10	Calibration	18
11	Typical calibration certificate.....	20

1 Applications

Typical use of the RIM-7499-BOM include applications such as:

1. General meteorology.
2. Water resources studies.
3. Hydrology.
4. Flood warning systems.
5. Automatic logging systems.
6. Remote and long-term logging deployments.

The RIMCO rain gauges are great solutions for rain measurement.

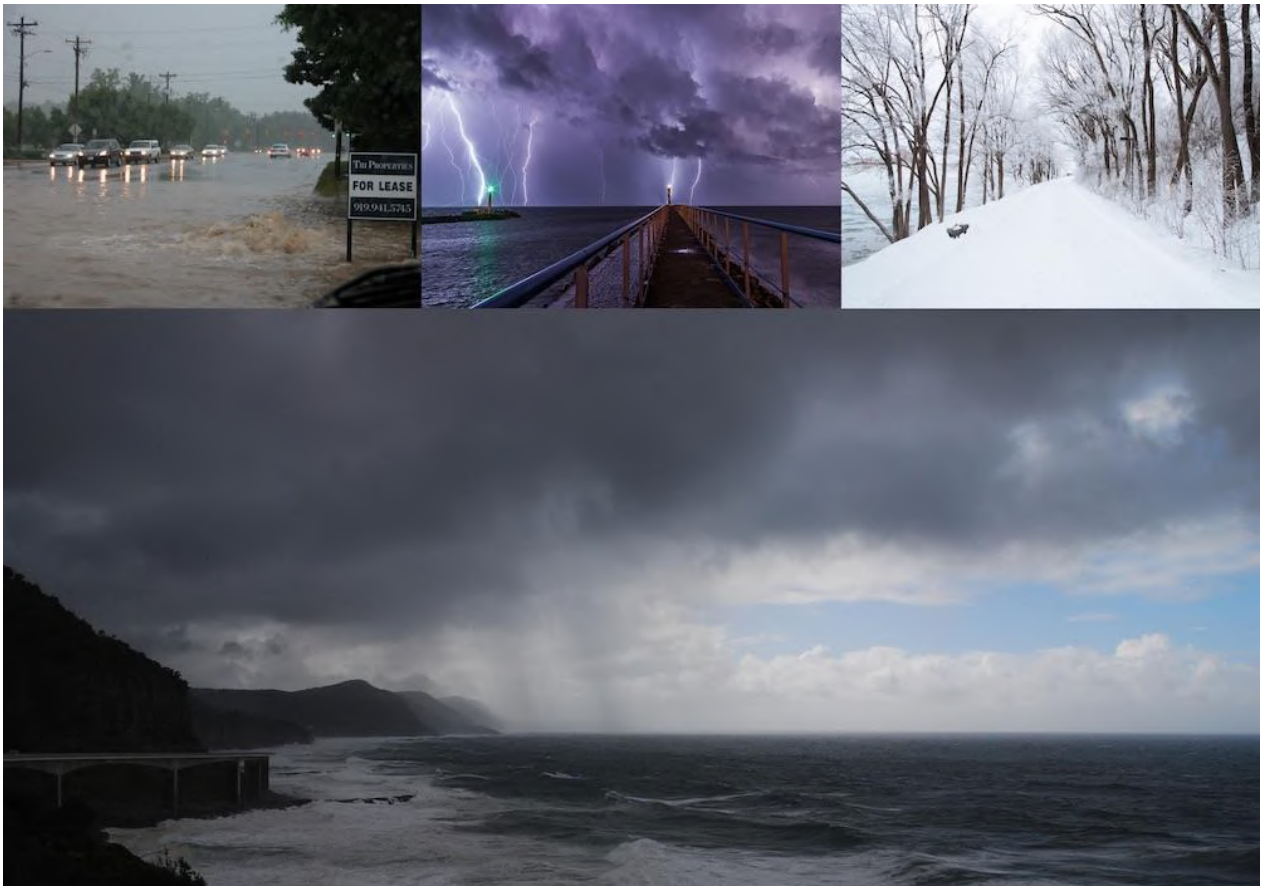

2 Safety



For correct functioning of the Observator RIM-7499-BOM, the rain gauge must be installed according to the installation instructions.



For correct measurement, perform regular service and calibration of the rain gauge.



Always install the rain gauge according to procedures.



After end of life, please dispose this product according to your local regulations or return it to the manufacturer.

3 Specifications

RIM-7499-BOM dimensions	
Length	315mm
Diameter	230mm
Net weight	5.5kg
Shipping body diameter	7.0kg
Volumetric weight	7.8kg
Packing carton	330x330x430mm
Mounting	3 holes threaded to 3/8" British Standard Whitworth (BSW) on 256mm diameter at 120° pitch. Will allow up to M8 bolts to pass through mounting holes.

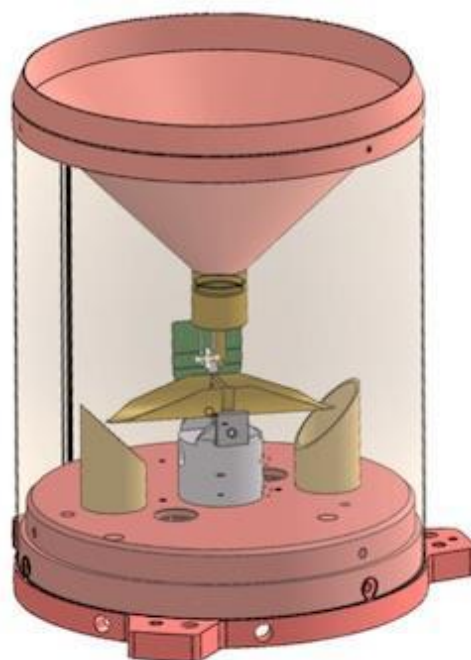
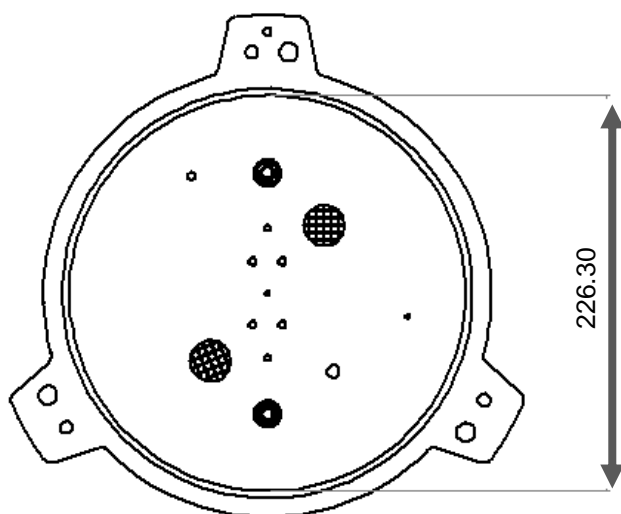
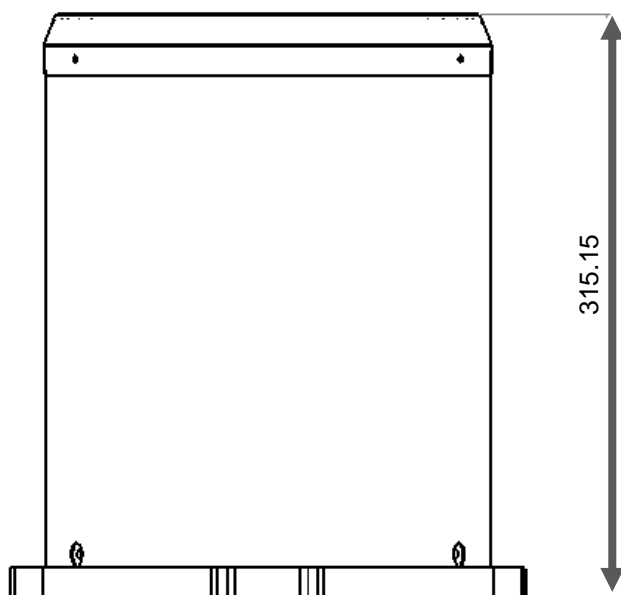

Specifications	
Collection diameter	203 ± 0.2mm.
Accuracy	±1% to 250mm/hr. +0 to -7% from 250 to 500mm/hr.
Resolutions available	0.2, 0.25, 0.5 or 1.0mm.
Contacts	One normally open magnetically actuated reed switch. Dual reed-switch assemblies available as an option.
Magnet	Rare earth type.
Reed switch rating	50V Alternating Current/Direct Current (AC/DC) @ 0.5A non-inductive.
Closure timing	50 milliseconds minimum. 150 milliseconds maximum. Maximum bounce time 0.75 milliseconds up to 350mm/hr.
Termination	Screw termination (2.5mm ²) and 4.8mm male spade terminations on reed-switch holder. 2m cable normally provided.
Switch protection	14mm Metal Oxide Varistor (MOV) across contacts, 30V and 8.5 joule nominal rating.

	Operating	Storage
Temperature	0°C to +50°C	-65°C to +55°C
Humidity	10% to 100%	5% to 100%
Wind	0 to 50km/hr (may affect accuracy)	0 to 180km/hr
Vibration	High, consistent with high winds.	High, consistent with shipping and handling.

	Operating	Survive
Precipitation	Heavy rain, hail or snow (may affect accuracy – as with all rain gauges).	Accumulation of up to 15mm of freezing precipitation accompanied by wind gusts of 100km/hr (may affect accuracy during this condition, but the rain gauge will continue to operate once extreme conditions have subsided).

Further specifications	
Shock	Will sustain a 1.3m drop in packing carton
Corrosion	Extremely low even in coastal environments
Electrostatic Discharge (EMI)/transient	To CE (EU), C-Tick (Australia/NZ) mark and ANSI C37.90a/ IEEE Std 472 (1974). May be affected by cabling arrangement between the rain gauge and the recording equipment.

4 Wiring diagram

The RIM-7499-BOM switch schematic is the following:

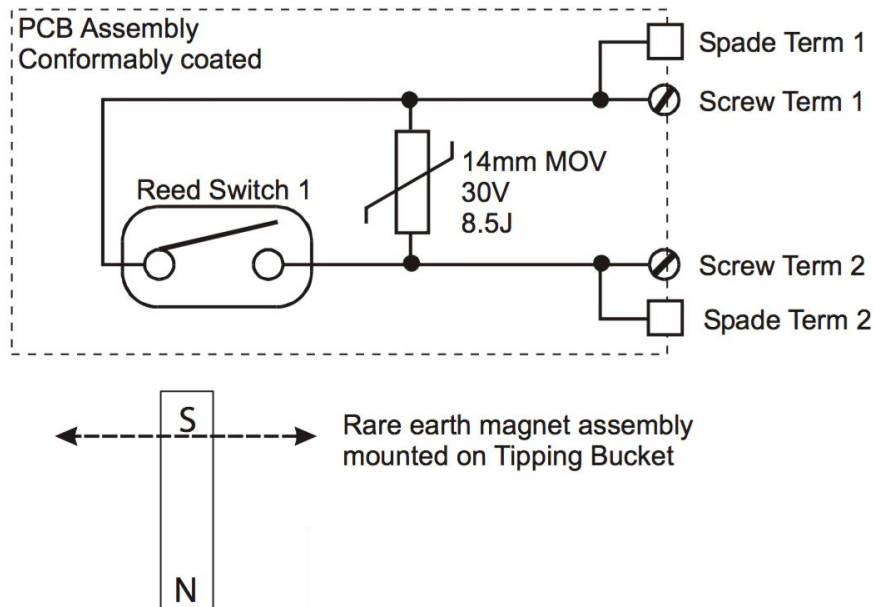

Notes:

- 1) Screw terminals can accept conductors up to 2.5mm².
- 2) Spade terminal is a standard 4.8mm male.
- 3) Contact closure is 50 - 150mS during bucket tip.
- 4) Contact rating 0.5A AC/DC resistive.
- 5) Contact life 10 million minimum.
- 6) The protection Metal Oxide Varistor (MOV) may be replaced with other two terminal protection devices as required.
- 7) Also available in dual version (SWH80-2).

5 What you will find in the box

When the product is delivered, this is what you will find in the box:



Items found in the box

RIM-7499-BOM rain gauge



Calibration certificate

OBSERVATOR		Observator Instruments Pty Ltd																													
instruments		11 Main Central Drive, Doreville																													
		PO Box 100, Doreville																													
Calibration Certificate																															
RIMCO RIM-7499-BOM STD Tipping Bucket Rain Gauge																															
Client:																															
Order Number:	001																														
Order Product Code:																															
Customer ref no:																															
Date of Calibration:																															
<table border="1"> <thead> <tr> <th colspan="2">Calibration Results:</th> <th colspan="2">Aggregated Measurements</th> </tr> <tr> <th>Nozzle dia. (mm)</th> <th>Aggr. flow (mm³/min)</th> <th>Run 1</th> <th>Run 2</th> </tr> </thead> <tbody> <tr> <td>0.5</td> <td>100</td> <td></td> <td></td> </tr> <tr> <td>0.8</td> <td>200</td> <td></td> <td></td> </tr> <tr> <td>1.0</td> <td>250</td> <td></td> <td></td> </tr> <tr> <td>1.5</td> <td>375</td> <td></td> <td></td> </tr> <tr> <td>2.0</td> <td>500</td> <td></td> <td></td> </tr> </tbody> </table>				Calibration Results:		Aggregated Measurements		Nozzle dia. (mm)	Aggr. flow (mm ³ /min)	Run 1	Run 2	0.5	100			0.8	200			1.0	250			1.5	375			2.0	500		
Calibration Results:		Aggregated Measurements																													
Nozzle dia. (mm)	Aggr. flow (mm ³ /min)	Run 1	Run 2																												
0.5	100																														
0.8	200																														
1.0	250																														
1.5	375																														
2.0	500																														
Notes: C1: Test at reference point C2: Test at reference point 100mm C3: Test at reference point 200mm																															
Job Number: Calibrated by:																															

5mm (across flats) hex key (for receiving cylinder removal)



The carton should be retained for storage and transit purposes. When transporting the rain gauge for calibration or repair purposes, it is best shipped in its original carton using the foam inserts. This will ensure that the rain gauge will not sustain damage due to normal transit handling and vibration.

6 Accessories

Observator Instruments offers a wide range of accessories for the RIM-7499-BOM. The range of products are available from the website:



Accessories

Field Verification Unit
RIM-FVU



Spare parts	
7499-B02	Bucket assembly 0.2mm for all RIMCO rain gauges.
7499-B025	Bucket assembly 0.25mm for all RIMCO rain gauges.
7499-B05	Bucket assembly 0.5mm for all RIMCO rain gauges.
7499-BRB	Bridge bearing.
7499-BRG	Complete bridge assembly including bearings and end plates.
7499-BUB	Bucket bearing for all RIMCO rain gauges buckets.
7499-FIL	Filter screen (leaf guard) for all RIMCO rain gauges.
7499-FUN	Funnel and RIM assembly for RIM-7499 series.
7499-JKT	Stainless steel outer jacket for RIM-7499 and RIM-8500 series.
7499-MAG	Magnet slug and arm for all RIMCO rain gauges
7499-ReedKit1	Single switch and magnet replacement kit for all RIMCO rain gauges.
7499-ReedKit2	Dual switch and magnet replacement kit for all RIMCO rain gauges.
7499-SWH-2	RIM-7499 dual reed switch kit — see 80SWH-2.
7499-SYP02B	Syphon 0.2mm for all RIMCO rain gauges.
7499-SYP02	Syphon 0.2mm for all RIMCO rain gauges.
7499-SYP025	Syphon 0.25mm for all RIMCO rain gauges.
7499-SYP05	Syphon 0.5mm for all RIMCO rain gauges.
7499-SYP10	Syphon 1.0mm for all RIMCO rain gauges.
7499-TCH	Thermostatically controlled heater kit (12/24V @ 4/2A).
7499-TX12	Heater transformer 240/12V AC, 50VA double insulated and fused.
7499-TX24	Heater transformer 240/24V AC, 50VA double insulated and fused.
7499-SWH-1	Reed switch kit for all RIMCO rain gauges.
7499-SWH-2	Dual reed switch kit for all RIMCO rain gauges.

Options	
Heating option	12 or 24V AC/DC (48W maximum) operation with electronic thermostatic control (P/N 7499TCH). Isolated power supplies to allow operation from 110V AC or 220V AC, 50/60Hz are also available (P/N 7499TX12 or P/N 7499TX24).
Counter option	Liquid Crystal 6-digit counter (self-powered) installed in body (P/N 7499-LCD).
Dual reed switch option	Dual reed switch assembly fitted (add suffix -2) to the rain gauge part number.

7 Installation

7.1 Installing the rain gauge

7.1.1 Site selection

The World Meteorological Organization (WMO) make the following comments regarding the location of a rain gauge:

- *“The location of precipitation stations within the area of interest is important, because the number and location of gauge sites determine how well the measurements represent the actual amount of precipitation falling in the area. For more detailed information, see the WMO guide to hydrological practices (WMO - number 168).*
- *In choosing a site, the systematic wind field deformation above an elevated gauge orifice, as well as the effects of the site itself on the air trajectories, should be considered.*

The effects of the former can be reduced by selecting a sheltered site, but not so sheltered that surrounding objects interfere sufficiently to cause a reduction of the precipitation collected. Preferably, however, the effects can be reduced by using a ground-level gauge for liquid precipitation or by making the airflow horizontal above the gauge orifice using the following techniques.

These are listed in the order of decreasing effectiveness:

- *In an area having homogeneous dense vegetation, the height of such vegetation should be kept at the same level as the gauge orifice by regular clipping;*
- *In other areas, by stimulating the effect by using an appropriate fence structure;*
- *By using wind shields around the gauge.*

The effects of the site itself can give rise to local excesses and deficiencies of precipitation falling onto the site. In general, objects should not be closer to the gauge than a distance twice their height above the gauge orifice. For each site the average angle of obstacles should be estimated and a site plan made. Sites on a slope or on the roof of a building should be avoided. The surface surrounding the precipitation gauge can be covered with short grass or gravel or shingle, but hard, flat surfaces such as concrete should be avoided to prevent excessive in-splashing. Sites selected for measurement of snowfall and/or snow cover should be in areas sheltered from the wind as much as possible. The best sites are often found in clearings within forests or orchards, among trees, in scrub or shrub forests, or where other objects act as an effective wind-break for winds from all directions.

The fact that data analysis is made easier if the same gauges are used and if siting criteria are similar should be a serious consideration in the planning for networks.”

Consequently, we recommend that rain gauges be bolted onto small concrete slabs in such a way that they are easily levelled on site and then securely fasten to stop movement due to vibration as well as minimizing theft.

7.1.2 Installation

The slab should be approximately 300mm x 300mm with three M8 stainless steel mounting studs set in at a 120° pitch on a 256mm diameter. The threaded studs should protrude at least 50mm from the base of the slab.

The rain gauge is then fastened to the bolts as detailed below.

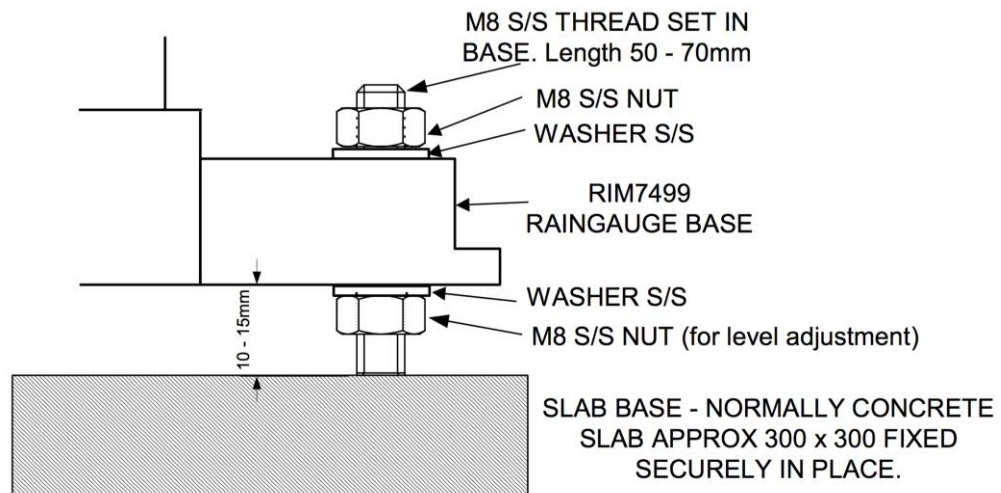

- a) Choose a suitable site and prepare a rigid slab for the rain gauge that allows discharged water to flow away freely. The rain gauge should preferably be installed on bolts mounted in a concrete slab (about 300 x 300mm) at ground level.
- b) Remove the rain gauge from its carton by opening the carton flaps at the top and removing the exposed moulded foam packing vertically. This will expose the rain gauge. The user manual, calibration certificate and 5mm hex-key are normally placed in the collection funnel when packaged in the factory – remove these. Carefully lift out the rain gauge vertically and place it on a stable bench or work area. Return the foam packing in the carton and store away, or dispose of, in an environmentally acceptable manner.
- c) Loosen the three-hex cap-head screws near the bottom of the stainless-steel jacket with the hex-key provided and carefully remove the receiving cylinder assembly by lifting it vertically. The copper receiving funnel may have already begun to oxidize (discolour) – this is normal and eventually the funnel will oxidize to a dull dark finish which is the ideal finish.
- d) If necessary, install the cabling and terminate on the switch assembly using either the screw terminations or the 4.8mm male spade connector.
- e) Screw on a stainless-steel nut on each of the threaded studs set into the concrete slab so that the bottom of the nut is about 5 – 10mm from the base of the slab. Then place a stainless-steel washer on top of each of the nuts.

- f) Position the rain gauge onto the slab so that the three-rain gauge mounting holes pass through threaded studs and rest on the stainless-steel washers. Place another stainless-steel washer on the stud (on top of rain gauge base) and loosely thread another nut on the three studs.
- g) Level the unit by adjusting the lower nuts until the bubble is in the centre of the vial. Secure the rain gauge to the base by tightening the top nuts on the slab studs and ensure the rain gauge remains level.
- h) Carefully remove the rubber band and the protective tissue paper from the bucket mechanism. Remove the foam bearing protector strips by gently pulling them whilst gently lifting the bucket. Do not touch the inside of the bucket surface.
- i) Connect the rain gauge to its recording device and gently tilt the bucket from side to side and ensure the recorder acknowledges one count for each bucket tip.

Caution: Do not touch the inside of the bucket.

- j) Carefully replace the receiving cylinder assembly and secure the three cap-head screws with the key provided. Do not over tighten.



Figure 7.A: Typical installation

7.1.3 Operation

The rain gauge is now ready for normal operation and should only require infrequent maintenance as described in the following chapter.

8 Operation theory

Rain falling on the 203mm collecting funnel is directed through a siphon control unit and discharges as a steady stream into a two-compartment bucket mounted in an unstable equilibrium.

- As each compartment fills, the bucket tilts alternately about its axis. Each tip forces a momentary contact closure by magnetic means corresponding to 0.2, 0.25, 0.5 or 1.0mm of rainfall according to the bucket capacity.
- The siphon discharge volume is normally adjusted to be nominally half that of each bucket compartment to ensure optimal timing performance. This is necessary when rain intensity measurements are required.
- Water discharged by each bucket compartment is passed through individual discharge outlets configured to allow for simple post measurement collection for confirmation purposes.

A simple schematic of the rain gauge is shown below.

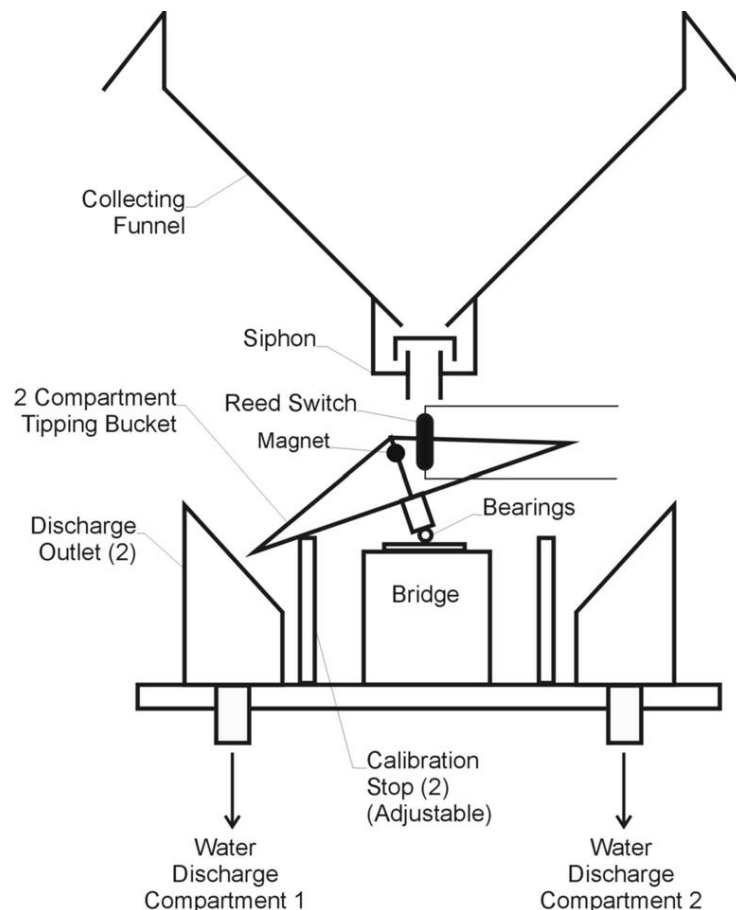

9 Maintenance

9.1 Maintenance strategy

The RIM-7499 series of rain gauges are designed for long term deployment with minimum maintenance required. The level of maintenance required is site specific and should be determined at time of installation. If the site is subject to falling leaves, then occasional clearing of the collection may be required as leaves drop there. Similarly, if the site is subject to dust then the siphon may require more regular inspection.

Below are some points to assist in the determination of a maintenance strategy for the rain gauges.

1. No lubrication is required on the bearing surfaces and they are normally self-cleaning. If necessary, remove any dust from the bucket bearings with a small soft hair brush.
2. The inside of the bucket may be cleaned with a clean soft cloth wetted with mild soapy water followed by a clean water rinse. Do not touch the inside surface with fingers or greasy substances as this will increase the surface tension of the rainwater resulting in higher counts (rainfall over-estimation).
3. To clean the siphon unit, remove the siphon by unscrewing it from the underside of the collecting funnel. Please note the siphon also holds the mesh strainer cylinder in position - this may be cleaned at the same time.
Unscrewing the slot inside the siphon anticlockwise will dismantle the siphon. The two parts may then be cleaned with a non-solvent cleaner such a detergent solution using a small stiff brush to remove dust and other debris. Use a pipe cleaner to clean the nozzle - never use an abrasive cleaner. Reassemble the siphon taking care not to over tighten the two siphon parts when screwing them together.
4. When testing the rain gauge with its cover removed, the test water must pass through the siphon which should be positioned approximately 5mm above the bucket.

10 Calibration

Calibration should only be performed by experienced users who intent to configure the sensor in a different mode.

Before calibrating the sensor, please read the RIM-FVU calibration manual available on [our website](#).

Basically, calibration of the rain gauges is implemented by discharging a known quantity of water into the rain gauge receiver funnel through a nozzle of known diameter and ensuring the number of bucket tips is within a defined range.

The nozzle diameter simulates a rainfall rate into a 203mm diameter receiver as tabled below:

Nozzle diameter (mm)	Rainfall (mm/hr)	(inches/hr)
0.40	16	0.63
0.60	36	1.42
0.75	59	2.32
0.90	109	4.29
1.00	127	5.00
1.15	194	7.64
1.30	273	10.74
1.55	350	13.78

Observator Instruments normally calibrates the RIMCO rain gauges using 0.6, 0.9 and 1.55mm nozzles placed nominally 400mm above the base of the rain gauge. The volume of water used is 650, 810, and 1,620cm³ as tabled below.

The results should be:

Bucket capacity	Bucket volume	Test quantity	Tips
(mm)	(cm ³)	(cm ³)	Number
0.2	6.48	650	100 ± 3
0.25	8.10	810	100 ± 3
0.5	16.2	1620	100 ± 3

- To allow for the possibility of some water remaining in the bucket and the siphon at the conclusion of a test, run the test at least three times and average the number of tips per test. This will reduce the error introduced by any water retention in the siphon and bucket.
- Make it a rule to begin all test runs with the bucket in the same starting position.
- Only adjust the stop screws after several measurement test runs have determined a calibration discrepancy.
- Checking calibration by measurement of individual measurement of bucket capacity is not satisfactory and introduces errors of up to 20%.

11 Typical calibration certificate

	Observer Instruments Pty Ltd ABN 56 007 283 963 8 - 10 Keith Campbell Court, Scoresby PO Box 9039, Scoresby VIC 3179 AUSTRALIA
<h3>Calibration Certificate</h3> <h4>RIMCO RIM-7499-020-STD Tipping Bucket Rain Gauge</h4>	
Customer:	
Model:	
Serial Number:	
Bucket capacity (mm):	0.2
Siphon Precision Orifice:	
Preliminary setting:	<input type="checkbox"/> 10 tips per side, 65 cm ³ each side
Calibrated at 0.9 mm:	<input type="checkbox"/> 100 tips per 650 ml at approx 109 mm/hr
Date of Calibration:	

Calibration Results:

Nozzle dia. (mm)	Approx. flow (mm/hr)	Aggregated Measurements		
		Run 1	Run 2	Run 3
0.9	109			
0.6	36			
1.3	273			
0.9	109			

Error allowed:

±1	tips at reference point
±2	tips at 36 mm/hr and 109 mm/hr
±3	tips at 273 mm/hr

Notes:

Job Number:

Calibrated by:



An Observer brand

Tel: +61 3 8706 5000 - Email: sales.au@observer.com - Web: www.observer.com

© Copyright – Observator Group

Since 1924 Observator has evolved to be a trend-setting developer and supplier in a wide variety of industries. Originating from the Netherlands, Observator has grown into an internationally oriented company with a worldwide distribution network and offices in Australia, Germany, the Netherlands, Singapore and the United Kingdom.